

LAYOUT PLAN WITH KHASRA IMPOSED

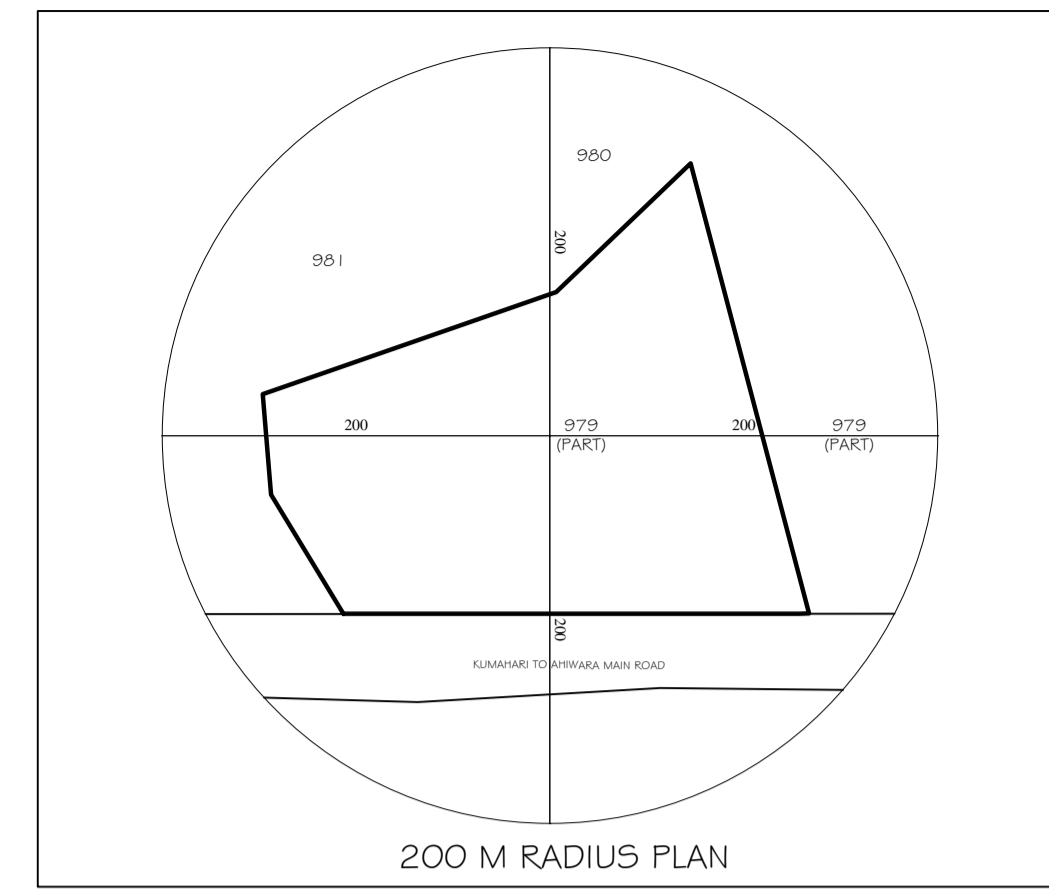

LAYOUT PLAN WITH ALL SERVICES IMPOSED



200 M RADIUS PLAN

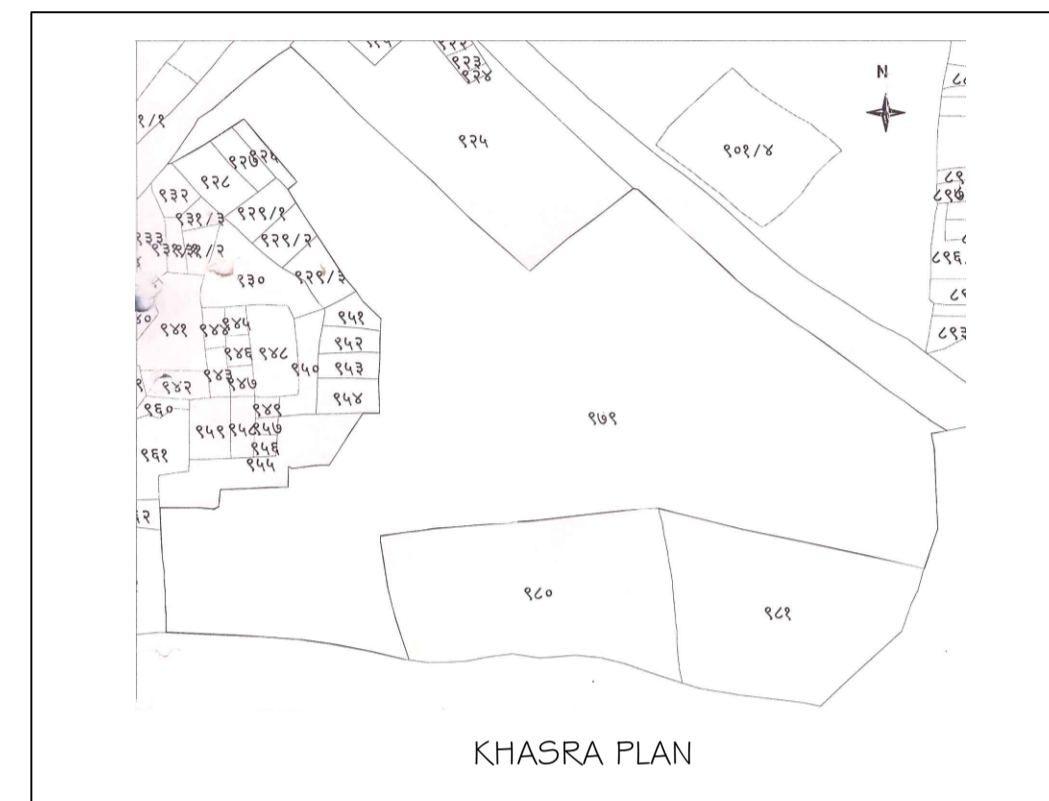

KHASRA PLAN

LEGEND FOR SEWERAGE LAYOUT

s.no	DESCRIPTION	SYMBOL
1	1500 Pipe	---
2	2000 Pipe	---
3	2500 Pipe	---
4	3000 Pipe	---
5	3500 Pipe	---
6	4000 Pipe	---
7	VENT PIPE	○
8	MAN HOLE	□

LEGEND FOR WATER SUPPLY LAYOUT

s.no	DESCRIPTION	SYMBOL
1	1000 Pipe	---
2	2000 Pipe	---
3	1500 Pipe	---
4	Distribution Pipeline to quarters	---
5	Scour Valve	⊕

LEGEND FOR RECYCLED WATER LAYOUT

s.no	DESCRIPTION	SYMBOL
1	RECYCLE WATER LINE	---

PROJECT

PROPOSED HOUSING FOR RAJIV NAGAR AVAS YOJNA VILLAGE-MURMUNDA, KUMHARI DURG

CLIENT

CHHATTISGARH HOUSING BOARD, RAIPUR .

CLIENT'S SIGNATURE

ARCHITECT'S SIGNATURE



TOWN PLANNER'S SIGNATURE

VINOD KUMAR
TOWN PLANNER
REG No. A-2004-110
B-31 PARVANA APTS
MAYUR VIHAR, PHASE-1
DELHI-110061

AREA STATEMENT

LAND AREA (A)	SQ.M.	PERCENTAGE OF C
AREA LEFT FOR ROAD/WIDENING (B)	4368.50 sq.m. = 10 Acres	
BALANCED PLOT AREA LEFT FOR COLONY (C)	38668.84	
PLOT AREA FOR PROPOSED BMS HOUSING (D)	5914.66	15.30
LAND AREA LEFT FOR DEVELOPING U/G(A), U/G(B), MIG AND COMMERCIAL PLOT (E=C-D)	32744.18	
PROPOSED OPEN AREA	4244.51	10.98
PROPOSED AREA OF COMMERCIAL PLOT (For Shops)	542.7	1.40
PROPOSED AREA OF ROAD	13428.18	34.76

ALL DIMENSIONS ARE IN METERS

STANDARD PLOT SIZE

BUILDING TYPE	PLOT SIZE (METERS)	NO. OF PLOTS	PLOT AREA (SQ. METERS)
BMS (1-55)	5.5 x 10.2	47	2636.7
U/G(B) (56-141)	7.6 x 12.2	71	6583.12
U/G(A) (142-210)	8 x 12	61	5856
MIG (211-226)	9 x 15.5	14	1953

OTHER PLOT SIZE

BUILDING TYPE	PLOT NUMBERS	NO. OF PLOTS	PLOT AREA (SQ. METERS)
BMS	1, 7, 13, 14, 24, 25, 33, 34	8	668.9
U/G(B)	56, 69, 81, 82, 86, 87, 91, 100, 101, 118, 119, 128, 134, 135, 141	15	1853.06
U/G(A)	142, 158, 159, 169, 170, 188, 189, 210	8	1044.92
MIG	223, 224	2	342.23

TOTAL NUMBER OF UNITS	226
TOTAL PLOT AREA	20937.93

OPEN AREA CALCULATION

OPEN	AREA (SQ. M)
1	551.25
2	1024.31
3	2688.95
TOTAL OPEN AREA	4244.51

REVISION NOTES

R0	01.12.21	FOR SUBMISSION
Suffix.	Date.	Details.
NORTH		SCALE

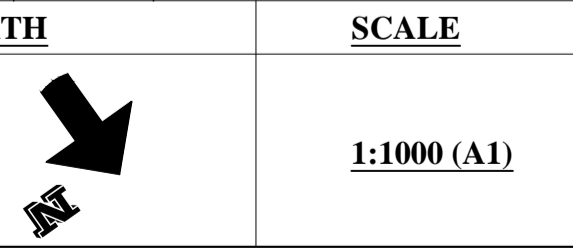

CONSULTANTS

DESIGN HORIZONS
REGISTERED ENGINEERS/PLANNERS/DESIGNERS
C-85, Freedom Fighters Enclave,
IGNOU Road, New Sarai, New Delhi - 110068
PH. : (011) 29534318, Fax: 29534318,
e-mail : info@designhorizonsindia.com,
designhorizons123@gmail.com
web : www.designhorizonsindia.com

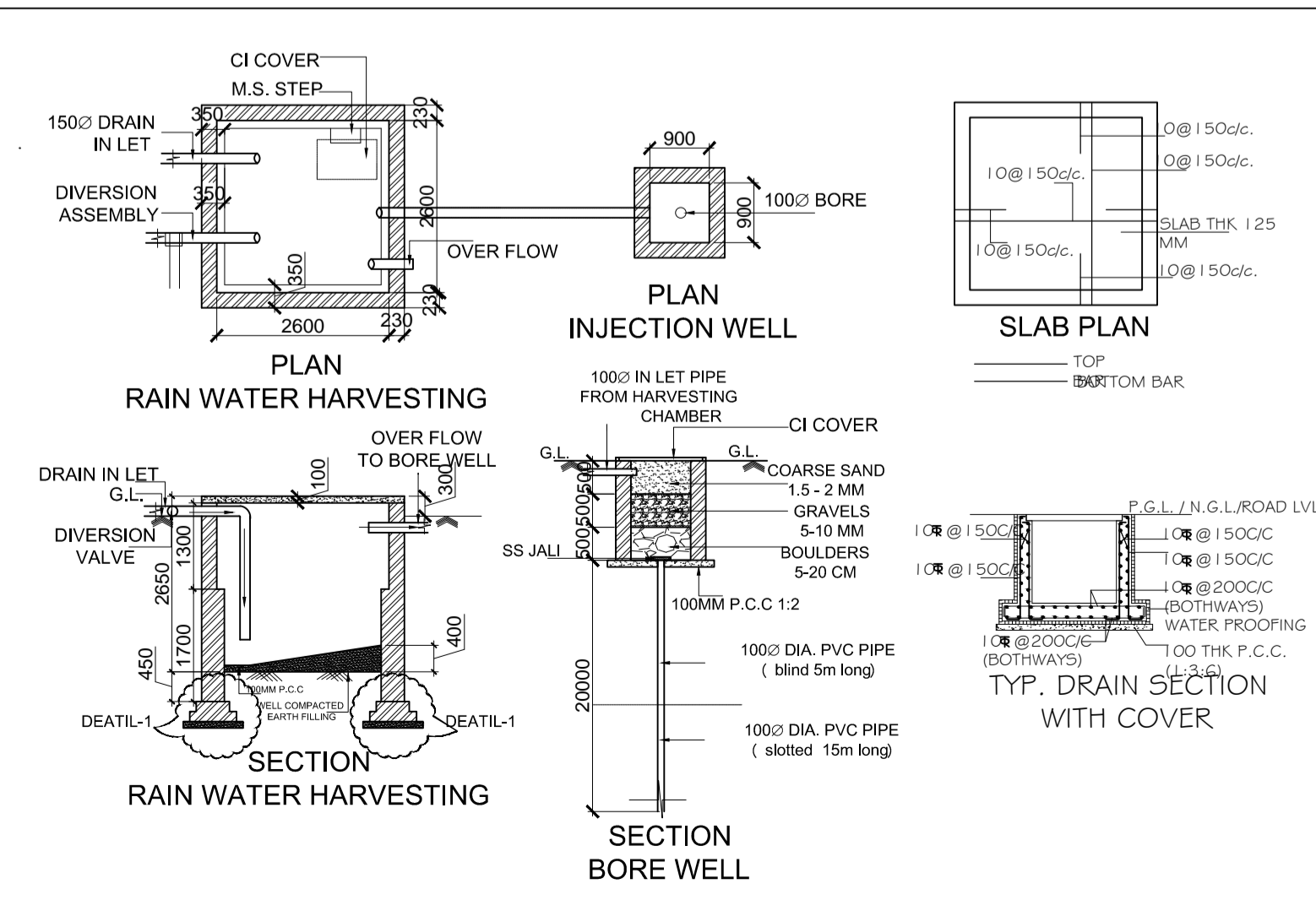
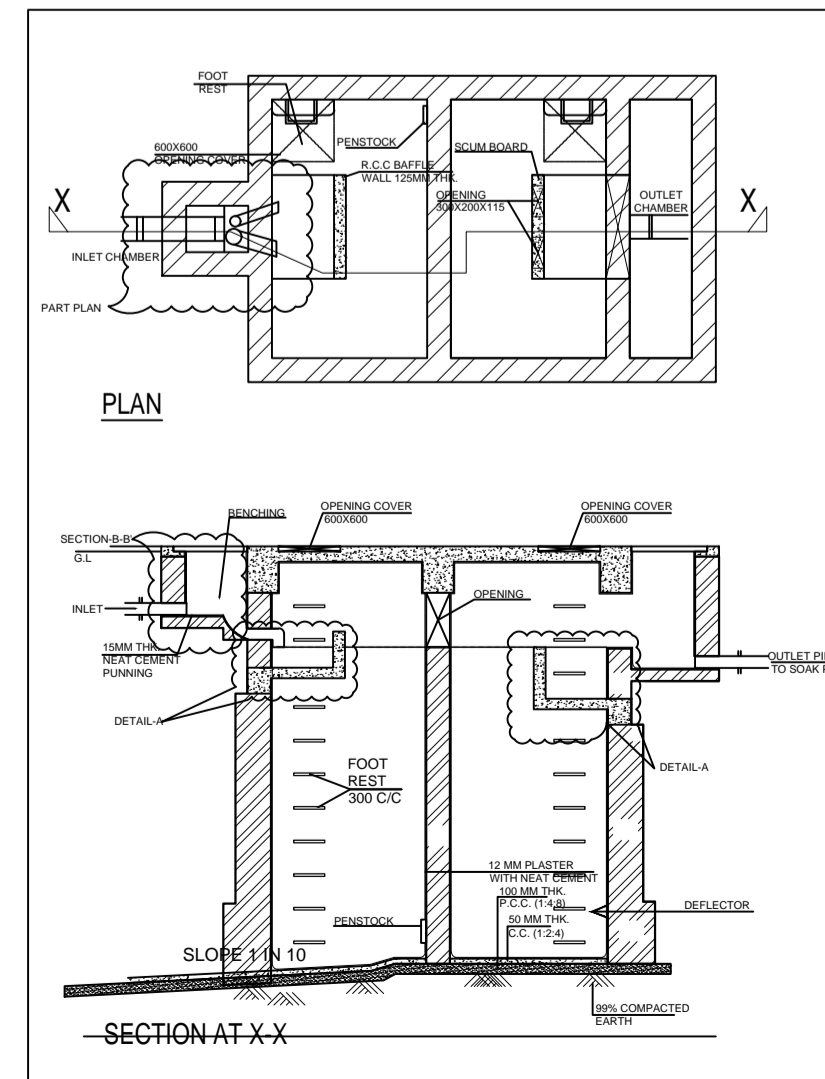

DESIGN HORIZONS
REGISTERED ENGINEERS/PLANNERS/DESIGNERS
C-85, Freedom Fighters Enclave,
IGNOU Road, New Sarai, New Delhi - 110068
PH. : (011) 29534318, Fax: 29534318,
e-mail : info@designhorizonsindia.com,
designhorizons123@gmail.com
web : www.designhorizonsindia.com